



# DW0001

## SPECIFICATIONS

■ Model:DW00-F05N-01

■ Appearance and Dimensions (mm)

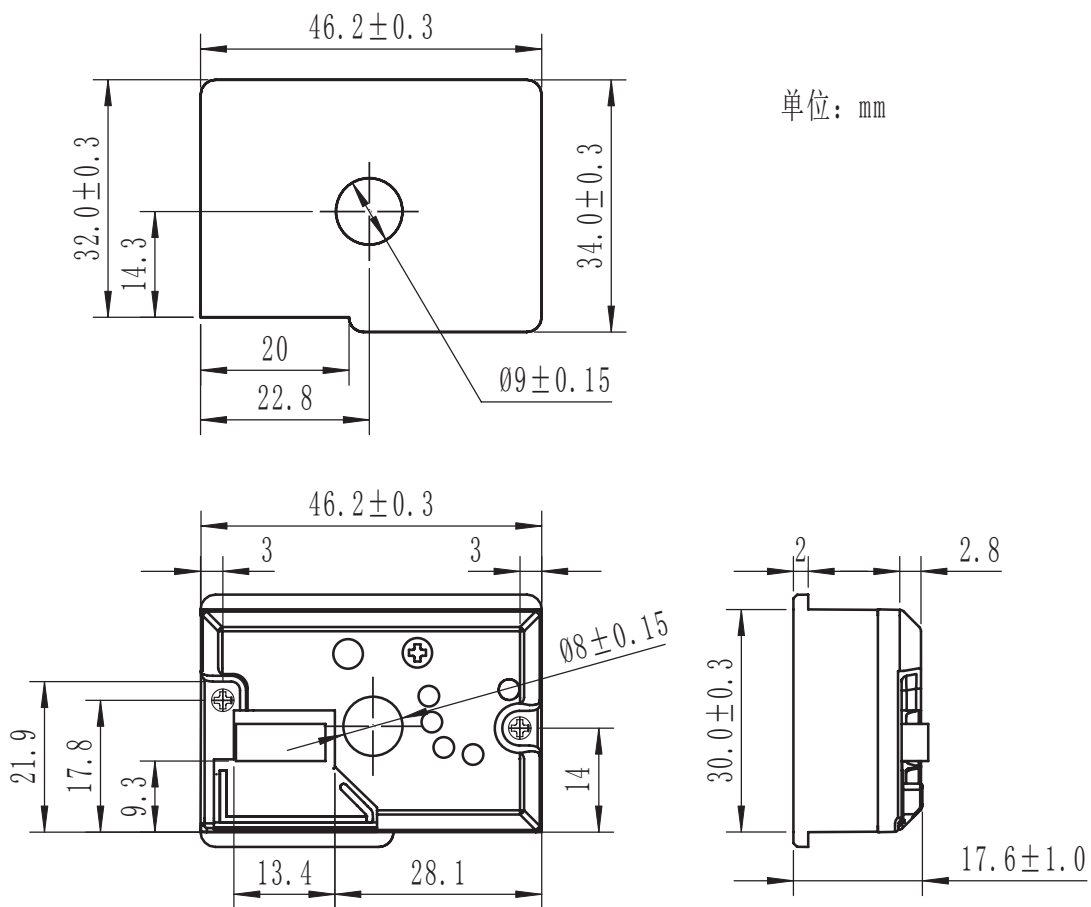

单位: mm

■ **Connection**

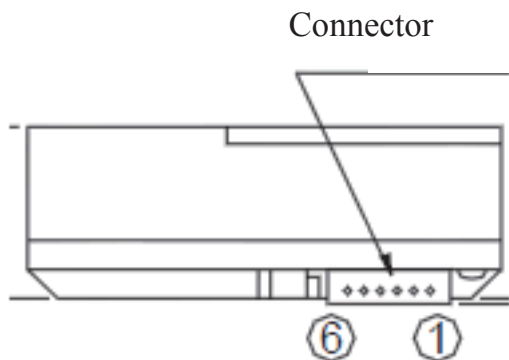

Connector	Mark	Definition
①	V-LED	LED Power Supply
②	LED-GND	LED Grounding
③	LED	LED Driving Pulse
④	S-GND	Grounding
⑤	Vo	Output
⑥	Vcc	Power Supply Voltage

■ **Electrical Parameters**

1. Absolute Maximum Rating

Parameter	Mark	Rated	Unit
Voltage	Vcc	-0.3to+7	V
Transmitting Tube Controlling Terminal	Vled	-0.3 to VCC	V
Operation Temperature	Topr	-10 to +65	℃
Storage Temperature	Tsol	-20 to +80	℃
Ripple Voltage	Vrp	Max100	mV

## 2. Electrical, Optical Characteristic

Parameter	Mark	Condition	MIN	TYP	MAX	Unit
Detectable Partical Diameter	D	*1 *2	1.0	2.5	—	um
Sensitivity	K	*1*2*3	0.35	0.5	0.65	V/ (0.1mg/m3)
Dustless Output Voltage	Voc	*2*3	0	—	1	V
Output Voltage (Vcc=5V)	VoH	*2*3RL=4.7kΩ	3.4	—	—	V
LED Transmitting Terminal Current	ILED	*2LED terminal voltage = 0	—	10	20	mA
Input Current	Icc	*2RL = ∞	—	11	20	mA

\*1 Sensitivity is specified by the amount of output voltage change when dust density changes by 0.1 mg/m3.

\*2 Input condition is LED input terminal

\*3 Output sampling timing pulse

## 3. Recommended transmitting tube controlling terminal circuit

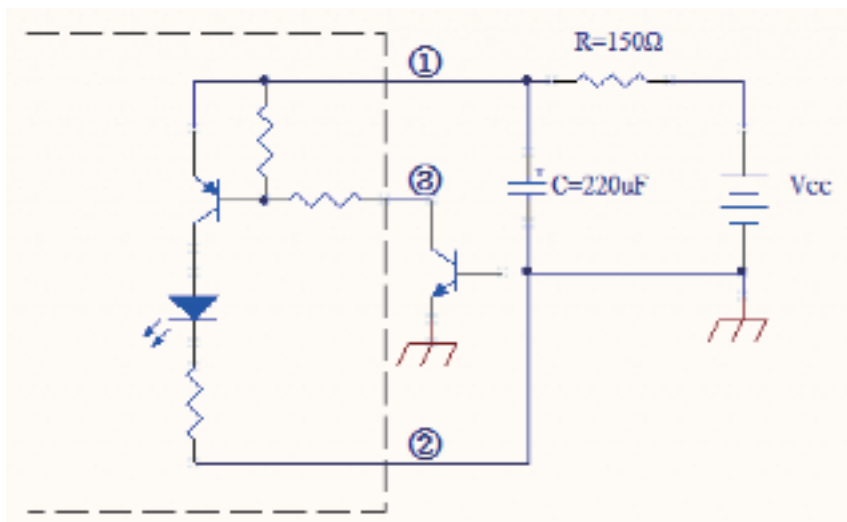

4. Transmitting tube controlling terminal and output pulse

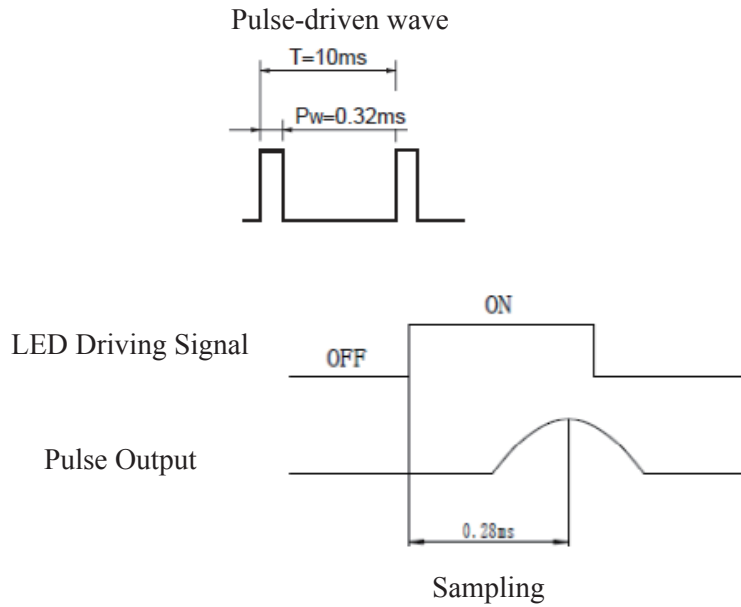

Recommended input condition for LED input

Parameter	Symbol	Value	R Unit
Pulse Cycle	T	10±1	ms
Pulse Width	Pw	0.32±0.02	ms
Operating Supply Voltage	Vcc	5±0.5	V

5. Output Voltage VS Dust density

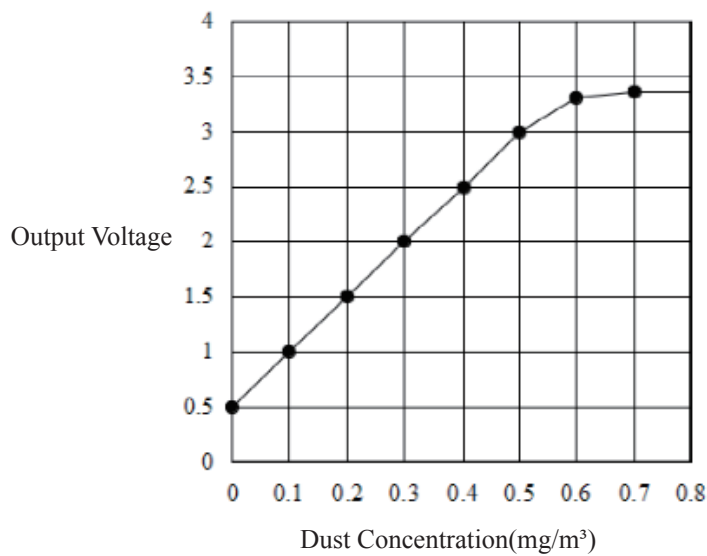

■ **Notice**

(1) Connection of housing and GND

Housing material use conductive resin and metal {test terminal side} as bottom cover. The metal case connects with GND in sensor.

(2) Cleaning

Please don't do cleaning, because the device might change its characteristics by cleaning.

(3) Pulse input requirements

Please input pulse and detection sequence according to the recommended graph

(4) Dust adhesion

The product may not detect the dust density correctly, when the dust adhered to the inside of hole that affects detecting space which consist of emitter and detector light axis. Please take the structure and mechanism of the equipment into consideration to avoid the influence of adhered dust. And when the dust is adhered, please consider the maintenance such as vacuuming or blowing off the dust by air.

In addition, please pay attention to structure and placing location of the application to avoid any adhesive particle like oil, etc. to gets into the device. If it sticks to optical part, malfunction may occur.

(5) Light output

In circuit designing, make allowance for the degradation of the light emitting diode output that results from long continuous operation. (50% degradation/5 years)

(6) Sensitivity adjustment VR

VR for sensitivity adjustment is set up at shipping from Audiowell. Please do not touch the VR or

Electro-optical characteristics specified on the specification will be invalid.

(7) Resolution

Please do not disassemble the device such as removing tapping screw and so on. Even if the device is reassembled, it may not satisfy the specification.

(8) Application to fire alarm

Please do not use this device for a fire alarm application. When using this device to application other than air purifying and equipment with air purifying function, please inform us before usage.

(9) Noise influence

If the sensor is located close to noise generator (ex. Electric dust collector, etc. ), the sensor output may be affected by leaded noise. On top of that noise from power supply line also may affect the sensor output. When designing the system, please consider the effect from noise.

(10) The sensor may change its value under mechanical oscillation. Before usage, please make sure that the device works normally in the application.

(11) Incident light influence

There is a case that the sensor output may be affected when outer-light comes through dust through hole on underside. In order to avoid any influence from outer-light, please locate the underside of sensor facing to inside of the application. In the test, must be in the bottom interface is tested under the condition of on reflection, avoid internal reflection of light affect the result of the test.

(12) About moist

When inside of the sensor is moisturized, this product does not keep its proper function. Please design the application carefully so that moisturization of the sensor does not happen.